

“Hold the line please...”

**First impressions
count!**

**For a professional
on-hold system with or
without a PBX?**

Read more



VGP 30, the first digital MOH system to work on any desktop phone



First impressions count... What your customers hear when you put them on hold will determine how long they are prepared to wait. So if they hear the soothing music & comforting messages of the new VGP30 they will stay on line for longer. The VGP30 is the first MOH system to work on any desktop phone. Giving any business of any size the professional feel of large company.

[Features](#)

[Versions](#)

[Technical details](#)



VGP 30, anything but conventional

[Front page](#)

[Versions](#)

[Technical details](#)



Some on-hold players allow you to play only one track. But the VGP30 is anything but conventional as it offers:

- **An instant push-button selection of 1 track out of 99 tracks, or play them all, in one big loop. Switch the built-in monitor on and listen to any pre-recorded audio track.**
- **“Trigger” play(*) so that your callers will hear the most important messages first. By pre-selecting a track you can deliver chosen messages, depending who is being put on-hold, or related to the day or period of a call.**
- **If your business expands and a PBX is installed, the VGP30 will not be a lost investment as it will perfectly function as a MOH on any chosen PBX. ▶**

voice
DIGITAL MEDIA
SYSTEMS **gear™**
your **Image** builder

(*) The trigger function cannot be used when the VGP30 is connected to a PBX

www.voicegear.be

VGP 30, multi-level on-hold Marketing

[Front page](#)

[Versions](#)

[Technical details](#)



For multi-level on-hold Marketing, simply plug a VGP30 into each specific handset (e.g. Sales dept., marketing, etc.). Connect another to your PBX as the companies main on hold system. ►



voice
DIGITAL MEDIA
SYSTEMS **gear™**
your **Image** builder

VGP 30 + VGP70 the ultimate combination

[Front page](#)

[Versions](#)

[Technical details](#)



Phones connected with the VGP30 playing your individual messages



Screen connected with the VGP70 playing your company slideshow



Phone connected with the VGP70 playing your company messages on the PBX

VGP 30, available in 3 versions

[Front page](#)

[Features](#)

[Technical details](#)

The Satellite version

- supplied with 3 pre-recorded MOH files

The Standard version

- with our **PineWoodStudio** software, allowing you to choose from 11 Royalty-Free music tracks and mix them with pre-recorded messages in 7 languages.

The Pro version

- also including our **gear2voice** software to generate spoken messages in a choice of 20 languages which can be mixed with the **PineWoodStudio** software.

VGP 30, owners manual

Front page

Features

Versions



For technical information
click on the owners manual.



voice
DIGITAL MEDIA
SYSTEMS **gear**TM
your **Image** builder



OWNERS' MANUAL

VGP-30

Multifunctional Digital Audio Player Music on-Hold System



.MP3
audio
.WAV



Table of content

	<u>Page</u>
Introduction:	2
Package content - optional equipment	2
Before starting the player - Selecting an audio track	3
Selecting your application - Connecting the VGP30 to a PBX	4
Connecting the VGP30 to a desktop phone - Compatibility list of desktop telephones	5
How to update MOH files onto the SD memory card using a PC	6
Download your MOH update files onto the SD memory card	6
Personalising your files	6
Some desktop telephones will not work immediately	7
How to operate the VGP30 with your telephone -	7
The advantage of triggering MOH files	7
Working with a headset system and the VGP30	8
Combining applications - Working with a stand-alone desktop phone	9
Multi level On-Hold Marketing	9
Call-, Contact- or Service Centres: playing back selectable audio files	9
Other applications : store casting/ In-store background audio/	10
Message triggering system in store casting applications	10
Locating the VGP30 - Installation template	11
Using the VGP30 on a desktop phone but away from the desktop	11

Terminology :

MOH : Music On Hold

PBX / PABX : Private Automatic Branch eXchange, commonly called, a telephone switchboard

Main Technical Specifications VGP30

Multifunctional Flash card audio player
 Reading Secure Digital (SD) cards of up to max. 2 GigaBytes (High speed not required but recommended)
 16 bit Mono Mp3 and Wav compatible - true CD audio quality
 Mp3 playback up to 320 kbps
 wav playback @ 22.040 Khz Sampling rate max.
 Up to 99 selectable audio tracks (size dependable)
 Bight LED display for track number readout
 Loop play on each individual track or all tracks (on 2 outputs)
 Line output (1) with adjustable output for PBX MOH audio input
 Max line output : 2V peak to peak - Internal 600 Ohm DC protection set by default
 Trigger enabled RJ-9 output (2) for playback on desktop phone or line In
 Switchable built-in monitor speaker
 Auto start after power down - On/Off switch via central volume knob on front panel
 External power supply : between 5 - 9 VDC, 350 mA max. (Polarity + on centre pin)
 Exterior dimensions : 180 x 120 x 34 mm H rubber feet incl. (connectors/plugs not included)
 Shipping weight : 0.8Kgr ; Nett weight player only : 0.32 Kgr

Authors' Rights

This product is supplied with **Royalty Free Music** from which the Authors' Rights were paid through the purchase of the hard- and/or software. Please familiarise yourself with the terms and conditions where this music can be used. This document will be sent to you after completing the questionnaire needed to activate the software and will be issued on the user and company name. In case of verification by the legal representatives of the Authors' Rights Association in your country, this form should be submitted to them. This form is strictly private and will not be transmitted to a third part in accordance with the privacy laws in your country.

INTRODUCTION

Thank you for choosing the **VGP30**.

The **VGP30**, multifunctional Digital Music on-Hold system will read MP-3 or WAV files from an "SD"(Secure Digital) memory card .

The **VGP30** provides access to innovative applications for many users.

1) It can be connected to the MOH audio input of a PABX.

2) It can play MOH audio on any desktop telephone :

- a) on an analogue desktop telephone (stand alone or as part of a PABX)
- b) on a system desktop telephone connected to a PABX (ISDN)
- c) on a desktop "VoIP", or IP-Phone

3) When connected to a desktop telephone it will play audio files in "trigger play" mode. The advantage of trigger playing is that the MOH files are started from the beginning (playing the most important messages first). On a PBX the MOH audio will start playing when a caller is being put on-hold, somewhere during the loop play.

This application gives access to "multi-level on-hold marketing, where a VGP30 can be connected to any PBX connected system telephone. Read more about this application further in this user manual.

IMPORTANT NOTICE : The VGP30 cannot be used with wireless telephones (DECT).

4) It can be used in store casting applications (music played in offices or stores with or without advertisements), as an announcement playback system connected to a PA system or audio pre/amplifier (using the trigger play mode)

PACKAGE CONTENT

The VGP30 is available in 3 versions :

The "**SATELITE**" version (Distribution dependable):

- contains the VGP30,
- a pre-recorded 256Mb SD flash memory card with 3 tracks of MOH mixed with welcoming messages
- an electronic version of the user manual in PDF format retrievable from the SD card.
- a connection audio cable to connect the VGP30 onto the MOH audio input of a PBX
- a short flat cable terminated on both ends with RJ-9 connectors to connect a desktop telephone to the VGP30
- a power supply adapter (240VAC/9VDC) in accordance with the country of sale

The "**STANDARD**" version:

Identical to the "SATELITE" version but comes with a PAYCODE which is noted on a separate page enclosed. This code will allow the installation of the **PineWoodStudio** software on a PC or laptop. Without the PAYCODE the program will only be able to run in a limited DEMO MODE version. If you have purchased a "SATELITE version" it is always possible to purchase the PinewoodStudio separately and receive a PAYCODE to have unlimited access. Please consult with your dealer.

The user manual of this software can be downloaded from our website at www.retellrecorders.co.uk Go to "products" and select "The **PineWoodStudio** (read more)" and click on the text which says to "download the owner's manual here". The program is supplied with 11 Royalty Free Music Tracks and welcoming messages in 7 different languages mixable with this software program.

The "**PRO**" version:

Identical to the "STANDARD" version but also contains the **gear2voice** program on DVD-ROM, giving access to a text-to-speech program in 20 languages in HQ. It also comes with the necessary USB dongle allowing the user to save up to 15 minutes of speech onto a computer HDD.

OPTIONAL EQUIPMENT:

- 1) MOH Audio output cables prewired with an RJ-45 connector to match specific PBX models (e.g.Alcatel, NEC and others)
- 2) An audio cable to connect the RJ-9 output (normaly going to the handset of a telephone) with an audio input (RCA/phono) e.g. of an audio mixing panel, or a preamp/amplifier

Please note that both cables are not commercialy available in conventional retail stores but can be purchased through your telecom's dealer on special order.

Voicegear Digital Audio Player VGP30 User Manual

BEFORE STARTING THE PLAYER

Before connecting the VGP30 please note that the "Secure Digital" flash card must be inserted in the slot as it will read from this memory card. All our units are supplied with a 256Mb SD card, pre-recorded with some MOH audio files. The files supplied are written in mp3 format but the unit can also read "wav" (@22.040 Khz sampling rate) formatted audio files. The SD card must be inserted into the card slot **BEFORE switching on the power of the player.**
WARNING : The SD card may be damaged if it is inserted after the player has been switched on.

The VGP30 can play any selected file out of a (max.) range of 99 files which can be stored on the SD card, as long as the memory size of the SD card is not exceeded. Therefore **each audio track must be allocated a three digit number (001- 002 - up to 099)** which then may be followed by the file name of your choice. Audio files which are not preceded with the 3 digits will not be played. The VGP30 can read SD cards up to a maximum of 2GB.

SELECTING AN AUDIO TRACK

On the top panel of the player a small LED screen indicates the number of the track which is, or which will be played, e.g. when the unit is used in trigger play mode and connected to a desktop telephone. By pressing the button next to the small LED window, a track can be selected by its track number stored on the SD-card. The selected track will be loop played. By pressing the selection button once more after that the last available track is selected, the LED window will display "AL" which indicates that the VGP30 will play all the stored files in a loop.

To monitor the track being played, switch the MONITOR switch from OFF to ON. If any mp3 or wav audio track has been stored on the SD card with a three digit prefix, the built-in loudspeaker will play the selected track. The playback volume in the middle of the front panel (next to the 3.5mm output jack) is used to adjust the volume output.

A copy of the User Manual is also stored as a PDF file on the SD card. The playback will not be interrupted by the presence of this data file on the SD card as it will not be identified as an audio file, and not preceded with three digits in front of the file name. We recommend however, to retrieve this file onto the PC or laptop of your choice as it will free additional storage capacity on your SD card, enabling to play more MOH audio files.

Front Panel View



Top Panel View

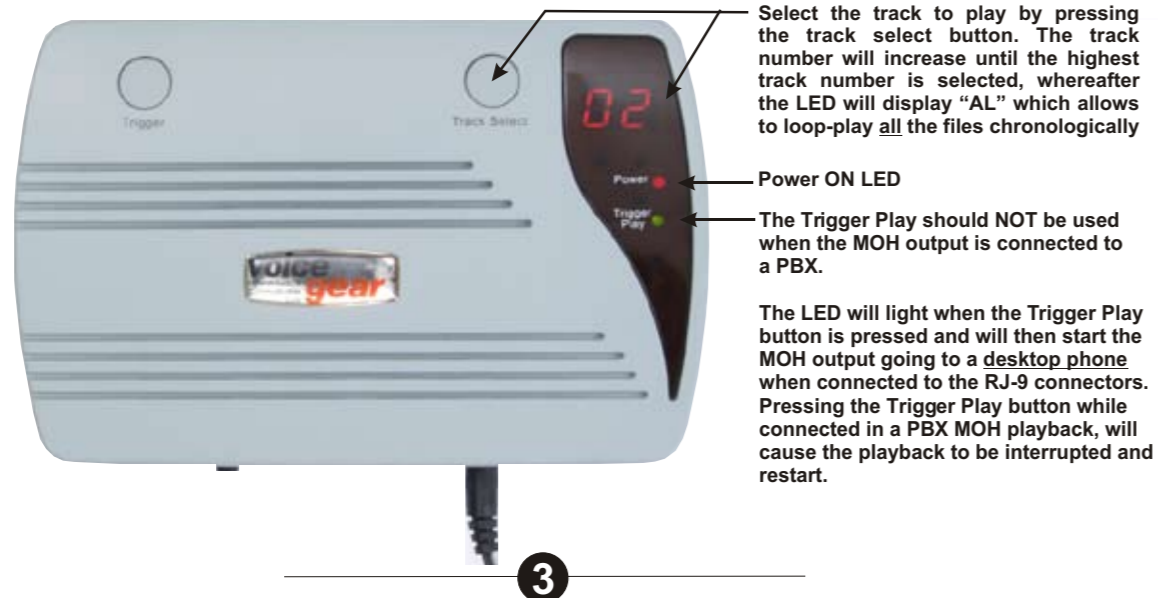

Voicegear Digital Audio Player VGP30 User Manual

SELECTING YOUR APPLICATION

There are two different kinds of audio outputs on the front of the VGP30: The first is labelled "To PBX audio" with a 3.5mm jack input and its volume control knob, in the middle of the front panel. The other is located on the left hand side of the front panel, and has two RJ-9 sockets which will allow a desktop phone to be connected to the VGP30. The volume output control knob is located next to the RJ-9 sockets.

The VGP30 will not be able to work in both ways simultaneously, and you should therefore choose between connecting directly to a desktop phone or to the audio port of a PBX.

CONNECTING THE VGP30 TO A PBX

The VGP30 has one 3.5mm jack output for connexion to the MOH input of the PBX. An audio cable, terminated with a 3.5mm jack on one end and with an RCA/phono plug on the other end is supplied with the unit for this purpose. See connection diagram below.

First make sure that the SD memory card is inserted and locked into the slot on the right side of the front panel. Now connect the power supply adapter supplied with the unit into the power input on the VGP30 and into the mains socket on the other end. The VGP30 has been designed to work with a power adapter providing between 7 to 12VDC (9VDC).

Now switch the power on by turning up the volume knob in the centre of the front panel, to the left. (To switch the power Off it should be turned to the right until it clicks) As soon as the power is switched on the LED window located in the top panel of the player will light up and will display red strips rotating in the LED window for a second and then display a track number e.g., "001" or any other track number.

- If no number appears on the LED screen it could mean either of the following :
- a) The audio file names are not preceded with a three-digit number (e.g. "001"...or" AL ")
 - b) There are no audio files on the SD card or files which can be recognised by the player.
 - c) The SD card has not been inserted deep enough to lock itself in the card slot. (Please do not use excessive force)

When the VGP30 has started reading the SD card, switch on the built-in loudspeaker, using the on/off switch located to the left of the front panel and adjust the volume output located in the middle of the front panel. The audio level going towards the MOH input of a PBX is adjusted with the same volume control. To adjust the audio level output which will be heard by correspondents when being put on-hold, there is a simple method: The person whom adjusts the audio level of the VGP30 should be called on a cell phone and then be put on-hold. Switch the Monitor switch on the VGP30 to OFF so that the MOH will only be heard through the speaker of the cell phone. The person using the cell phone will then be able to optimise the audio level output.

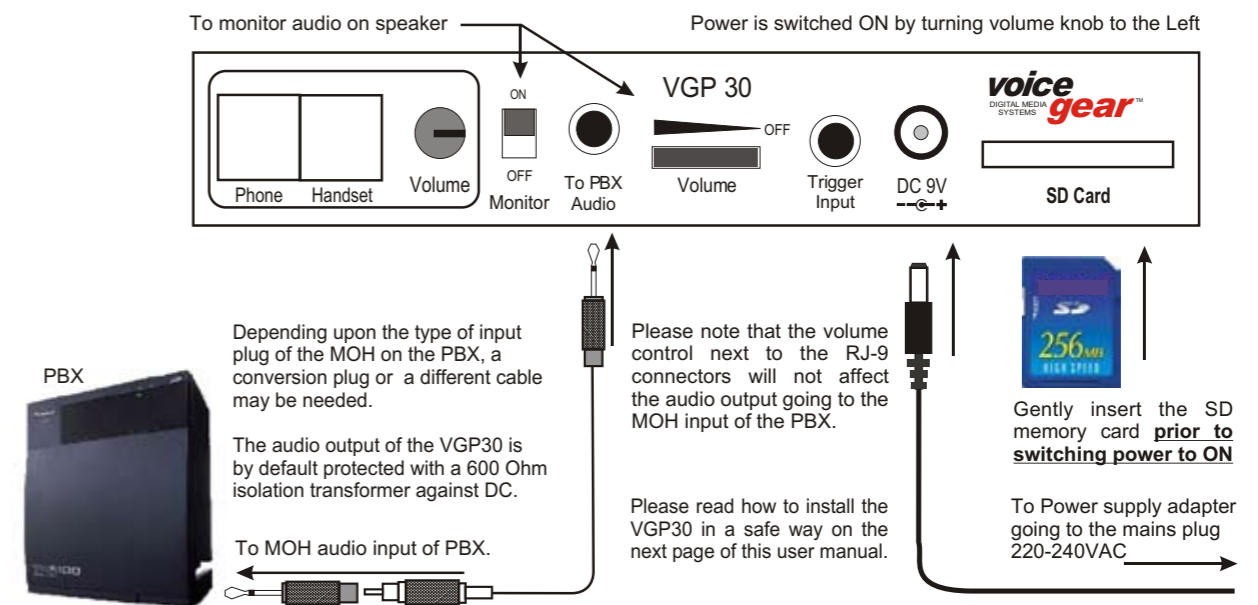

Voicegear Digital Audio Player VGP30 User Manual

Connecting the VGP30 to a desktop phone

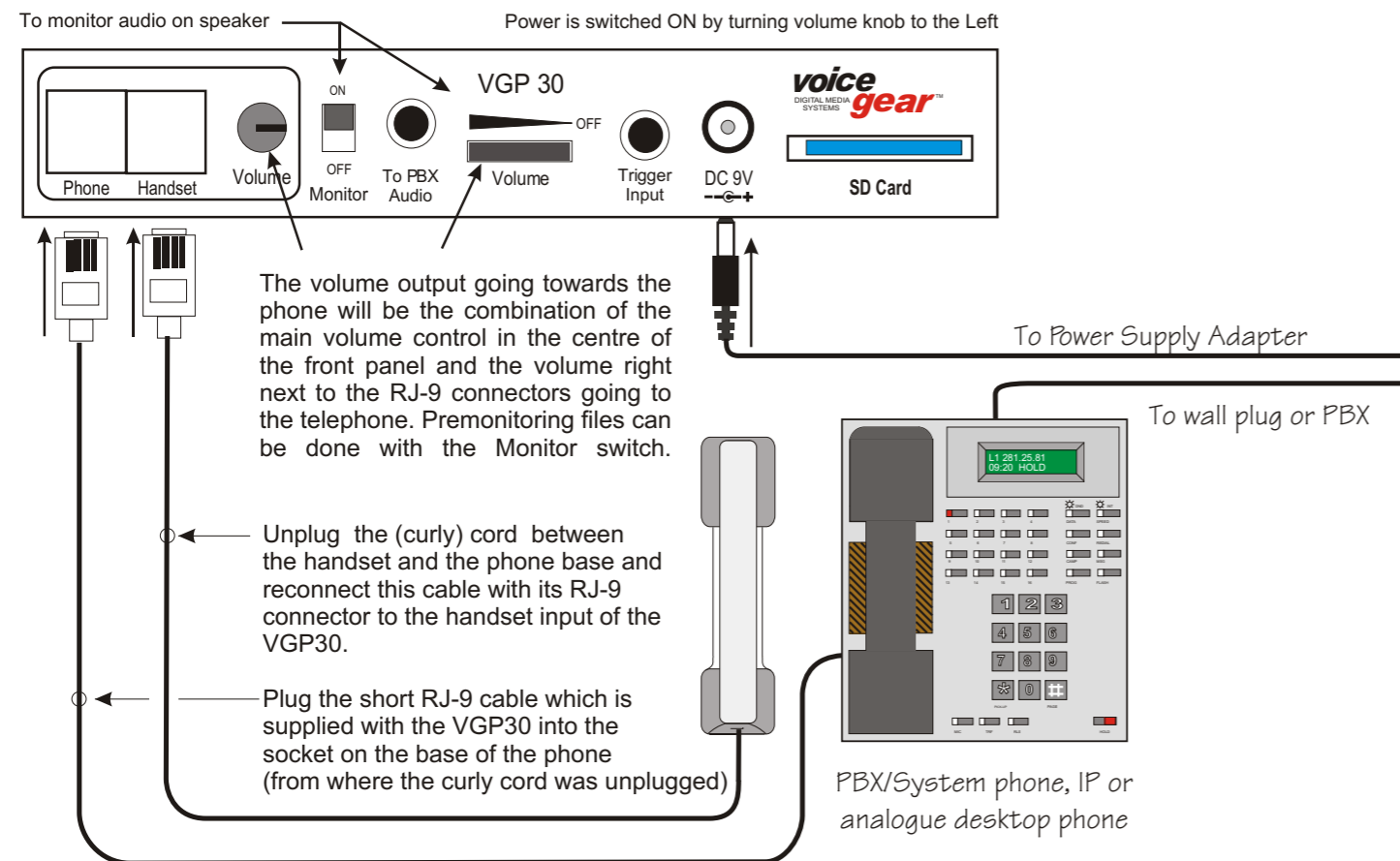

Which trade marks of desktop telephones are compatible with the VGP30?

90% of the “big brands” desktop telephones can be connected directly to the VGP30 without any technical intervention. Please find hereunder the list of manufacturers which follow the international RJ-9 standard, used to connect the curly cord between the receiver and your telephone. Due to differences in national distribution this list may vary accordingly. If the brand of your desktop telephone doesn't appear on this list, please contact your telecoms dealer.

TRADE MARKS IN ALPHABETIC ORDER:

AASTRA	ERICSSON	NORTEL
AEG	ELMEG/FEG	PANASONIC
AGFEO	GESCO	PHILIPS/NEC
ALCATEL	HAGENUK	SAMSUNG
AUERSWALD	ITT	SIEMENS
AVAYA	MATRIX	TENOVIS
BOSCH	MITEL	TIPTEL
CISCO	NEC	
DéTéWé	NEXTEL	

Voicegear Digital Audio Player VGP30 User Manual

How to update MOH files onto the SD memory card using a PC.

The SD(Secure Digital) format is popular as it is small and available in many larger capacities up to several gigabytes. The VGP30 reads WAV and MP-3 files alike. If your computer is not fitted with a card reader for SD flash cards, an external (or maybe even internal) card reader should be installed. Contact your telecom's dealer for further details .

If you wish to add a new audio file onto the existing files on your card, simply copy it from your computer onto the SD card and give it a 3-digit prefix which follows the existing files. (E.g. You have 3 files so your new file should be named 004) followed by a file name to make the identification of the file easier afterwards. The “drag & drop” method is also available to install new files, as long that you have given your files the right prefix.

To delete a file on the flash card, simply click on the file and click the DELETE command with mouse or keyboard.

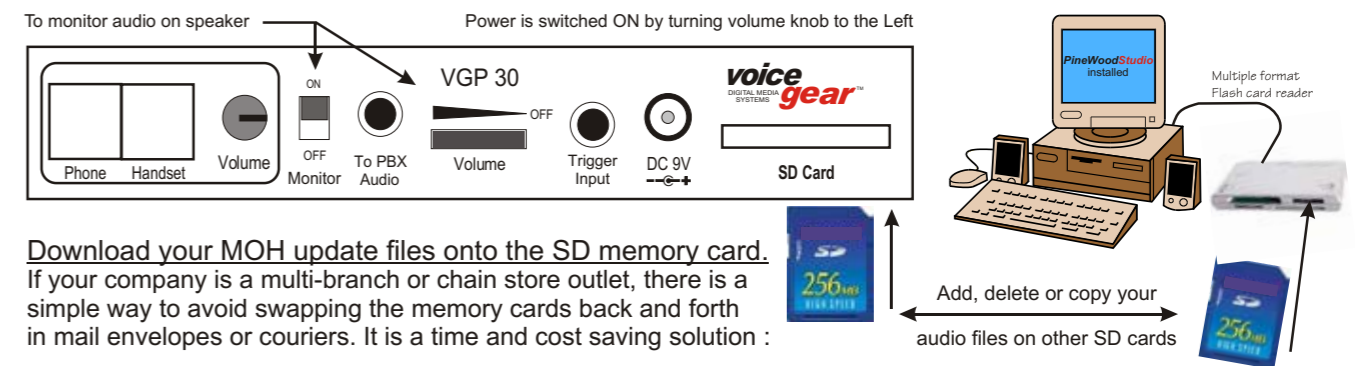

Voicegear Digital Audio Player VGP30 User Manual

Some desktop telephones will not work immediately...

90% of the desktop phones will not need any technical assistance as they will be wired as shown below:

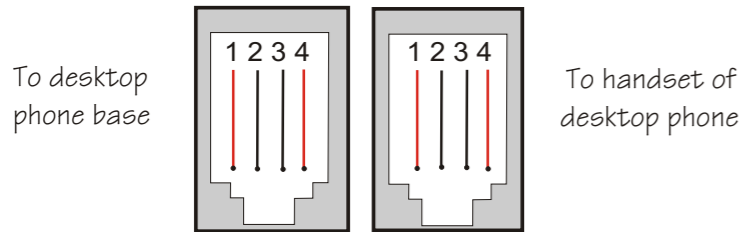

The RJ-9 connector carries 4 contacts used to connect the telephone circuits between the PCB of the phone and the handset. Often a curly cord is wired between the RJ-9 connectors. If the international standard is followed, then connector pins 1 and 4 are used to connect the microphone of the receiver and pins 2 and 3 will connect the loudspeaker inside the handset.

Visit www.voicegear.be for a compatibility list or e-mail info@pinwoodelectronics.com

How to make the other 10% work...

If your VGP30 needs to be adapted, this can be done by a qualified telephone Engineer. Alternatively, your distributor can supply a replacement connection lead, or pin out information.

How to operate the VGP30 with your telephone

You can install the VGP30 next to your telephone so that you can see the track number as appearing on the LED screen as well as the green trigger pilot light.



Preparing and testing your set up:

After having inserted the flash card and switched the power on, select a track for playback and make a call to a nearby cell phone. Press the trigger switch and listen to what you hear on the cell phone.

The volume output is a combination between the master volume (centre of front panel) and the volume knob on the right hand side, next to the RJ-9 connectors.

During the playback of the MOH, the microphone of the desktop phone is being muted so your correspondent will not hear you while he is on-hold. To resume the conversation press the Trigger button to stop the playback over the phone.

The advantage of triggering MOH files:

MOH are generally played in loop, accessing the file at random. When a MOH is "triggered", the file is played from the very beginning, starting with the most important messages, followed by the messages of decreasing importance. By using the track selector, a different track can be triggered played, containing additional information or if when e.g, different languages may be needed.

Voicegear Digital Audio Player VGP30 User Manual

Working with a (wired or wireless) headset system and the VGP30

Please refer to the diagram and connecting sequence below:

- 1) Connect the headset to the amplifier (wired systems only)
- 2) Connect the telephone handset to the headset amplifier.
- 3) Connect the headset amplifier output to the handset input of the VGP30 (RED circuit)
- 4) Connect the PHONE output of the VGP30 to the base of the desktop telephone (BLUE circuit)

IMPORTANT REMARK:

It is possible to mute the microphone during a conversation but advisable to use the VGP30 playback for longer on-hold periods. During the playback the microphone output is automatically muted on the VGP30 so no further muting is required.

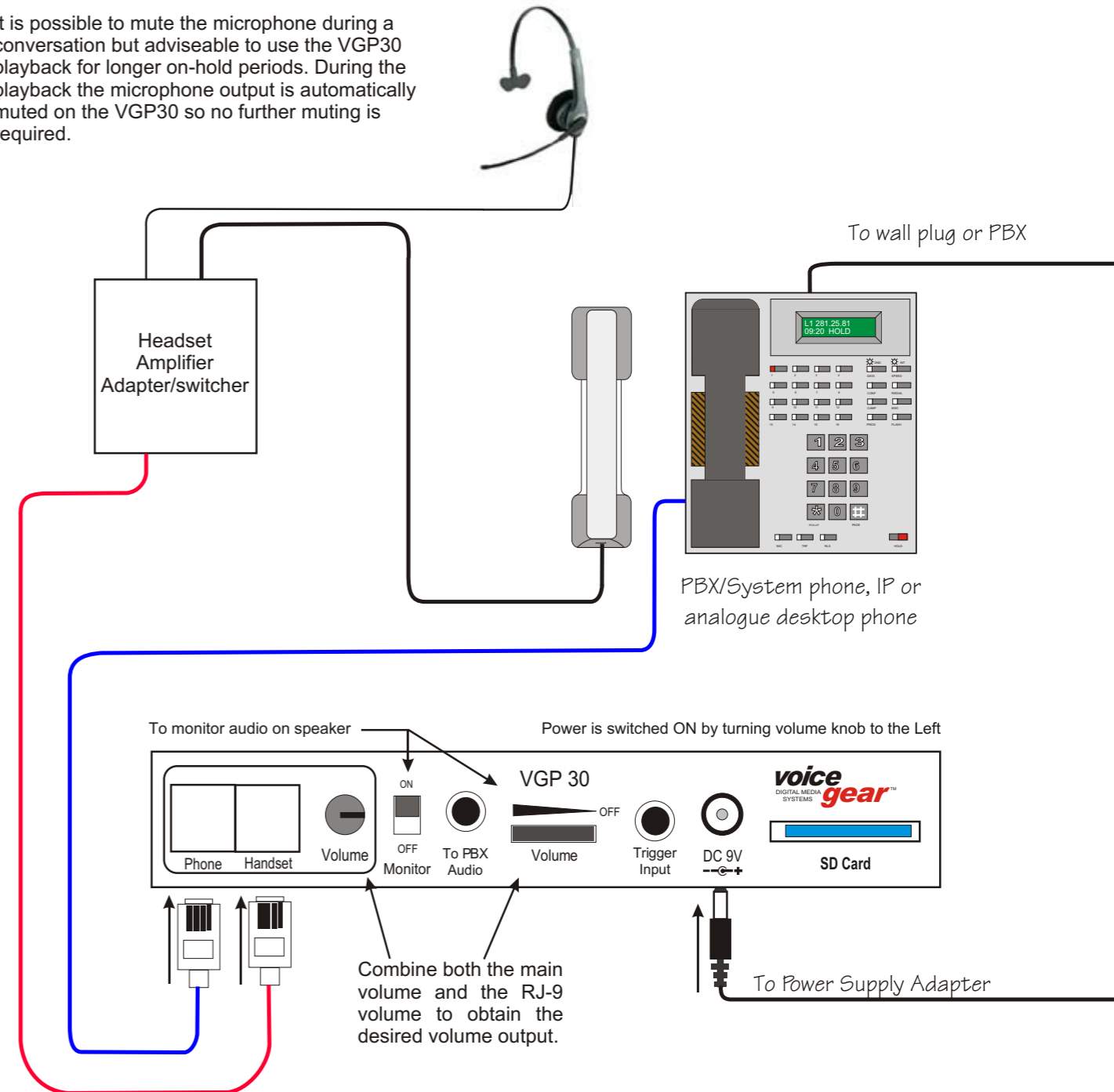

Voicegear Digital Audio Player VGP30 User Manual

Combining applications :

Working with a stand-alone desktop telephone

If you have no telephone switchboard (PBX) the VGP30 can be connected to any type of stand alone desktop phone, such as an analogue phone, a desktop VoiP or IP Phone, or even a digital desktop phone .

The working principal is simple : the desktop phone is connected to the VGP30 by means of its "curly cord" cable which connects the handset to its phone. Inside the handset, there is a microphone and a loudspeaker and when the caller is being put on-hold, the VGP30 is playing MOH while the microphone is being muted.

So if you are working from a home office or running a small business, a retail store or maybe a small service company, you no longer need a PBX to put your callers on-hold. And if your business grows, the same VGP30 can be connected onto a PBX enabling you to handle more calls.

Multilevel On-Hold Marketing

The versatility of the VGP30 can take you a step further : Although your PBX may already have a MOH system to put your callers on-hold, it can not play specific messages related to each department of that company. Medium sized or large businesses are divided in different departments for specific activities such as marketing, sales, shipping, accounting etc.

If a department manager would like to e.g. increase the sales of some specific products, they may find it an interesting idea to play MOH with messages promoting these products. So only the people who need to hear these messages like dealers and resellers, could be put on-hold when calling upon this specific department or telephone extension. People whom would be wrongly directed could be put on-hold while being transfered, on the main MOH system of the PBX. Let's not forget that the VGP30 can play a number of selected tracks so it also possible to play pre-selected info e.g. In different languages, on different products or subjects. The SD card can then also be updated easily and without spending much money, the VGP30 will become an interesting way to develop your business.

Call, Contact or Service centres : playing back selectable audio files

Call or contact centre collecting orders or in help-desk environments sometimes need to access a selection of pre-recorded audio/MOH tracks when putting their correspondents on-hold.

This may be the case when e.g. the MOH file should be related to the company whom entrusted the call or contact centre to speak to their customers. The operator can select a track which is related to the job performed. Each operator can play the file needed and as SD memory cards can be changed, it is a matter of a few seconds of putting the right SD card in the right VGP30 so that the operators can do the job they are given to do.

Public services, such as certain police departments dealing with foreigners may have use of playing usefull information over a telephone in different languages. Middle sized PBX systems cannot perform the playback of several and selectable audio files. This type of demand can generally be supplied by the more expensive PABX systems and generally the number of accessible files is limited and not accessible easily by call agents.

Voicegear Digital Audio Player VGP30 User Manual

Other applications : store casting system / in-store background audio

Please see the wiring diagram below:

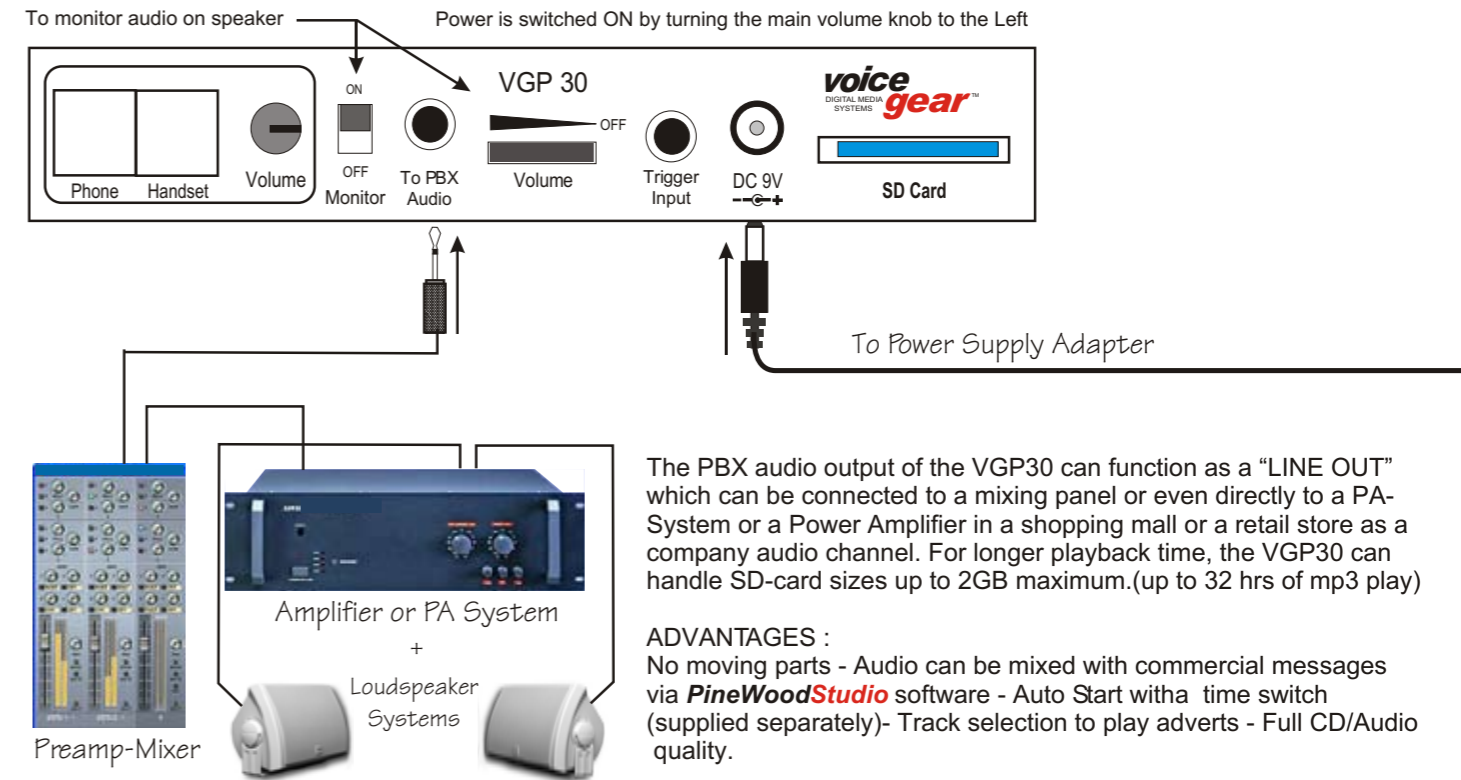

Other applications : message triggering system in store casting applications

Instead of using the PBX audio output, the PHONE RJ9 output is used to connect to an audio mixer, similar to the system shown above. By selecting any of the 99 tracks, pre-recorded messages can be triggered onto an in-store audio system. The built-in loudspeaker allows monitoring and the played audio track is only heard over the in-store audio system when the chosen track is triggered.

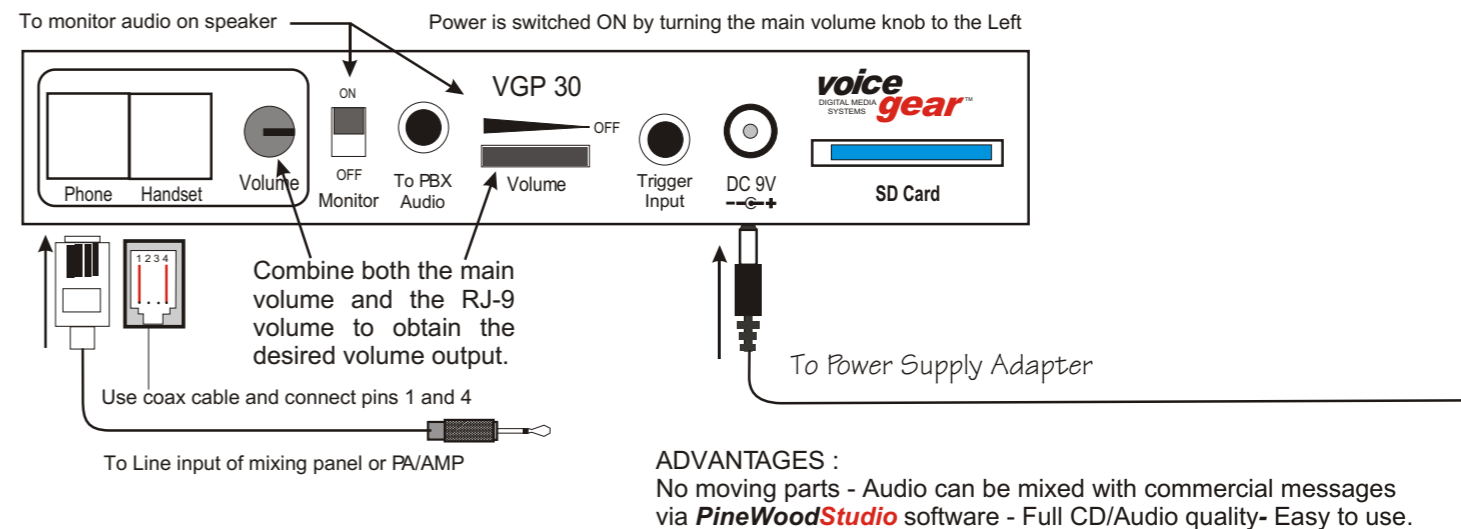

Voicegear Digital Audio Player VGP30 User Manual

Locating the VGP30:

The VGP30 can simply be placed on a shelf or inside a rack mount cabinet. The unit can also be mounted vertically, on a wall or shelf by placing two screws which will allow the unit to be hung with its front control panel downwards. This will protect the player from water and dust ingress. It also allows viewing the current track being played. The volume control will not have to be handled frequently and connecting cables, once inserted, need no further care. Use the template below for wall mounting the unit. Keep the player away from vibrating surfaces, dust, air vents and humidity. The VGP30 doesn't need special care. Please use a simple dry cloth to clean and remove dust.

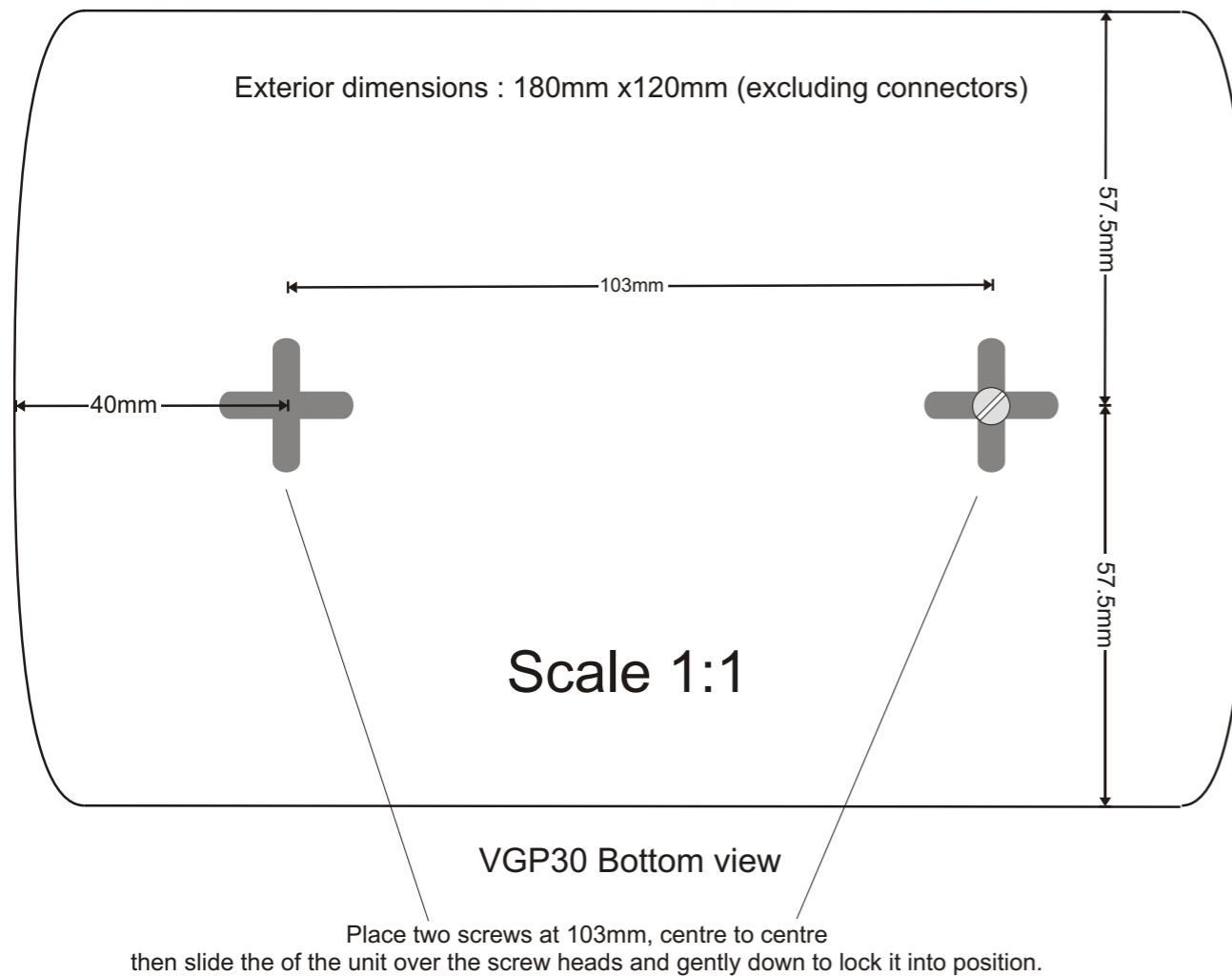

Using the VGP30 on a desktop phone but located away from the desktop

If there isn't enough desktop space and the VGP30 could not be installed next to your phone, you may have to install the VGP30 in a more distant location, on a shelf or maybe behind a computer or laptop. Here is how to do it :

As long as the "curly" cord of the telephone and the cable connecting the VGP30 to the base of the telephone can be replaced (up to 1 or 2 meters) both the telephone and the VGP30 will work without any problems. As the trigger knob can no longer be easily reached, an additional cable should be custom made by your dealer or may even be ordered as an accessory at a later date : This new cable should be plugged into the "Trigger Input" located in the middle of the front panel on the VGP30. This cable should be terminated with a 3.5mm (mono) phono jack on one end and a "push to lock" switch on the other end. This should be carried out by a qualified telephone engineer, alternatively a suitable cable and switch can be supplied by Retell Ltd.

Doing business in Europe ?



We will announce it for you in 20 languages!